

THORENS

"Masterpiece"

Turntable
and record changer
TD 224

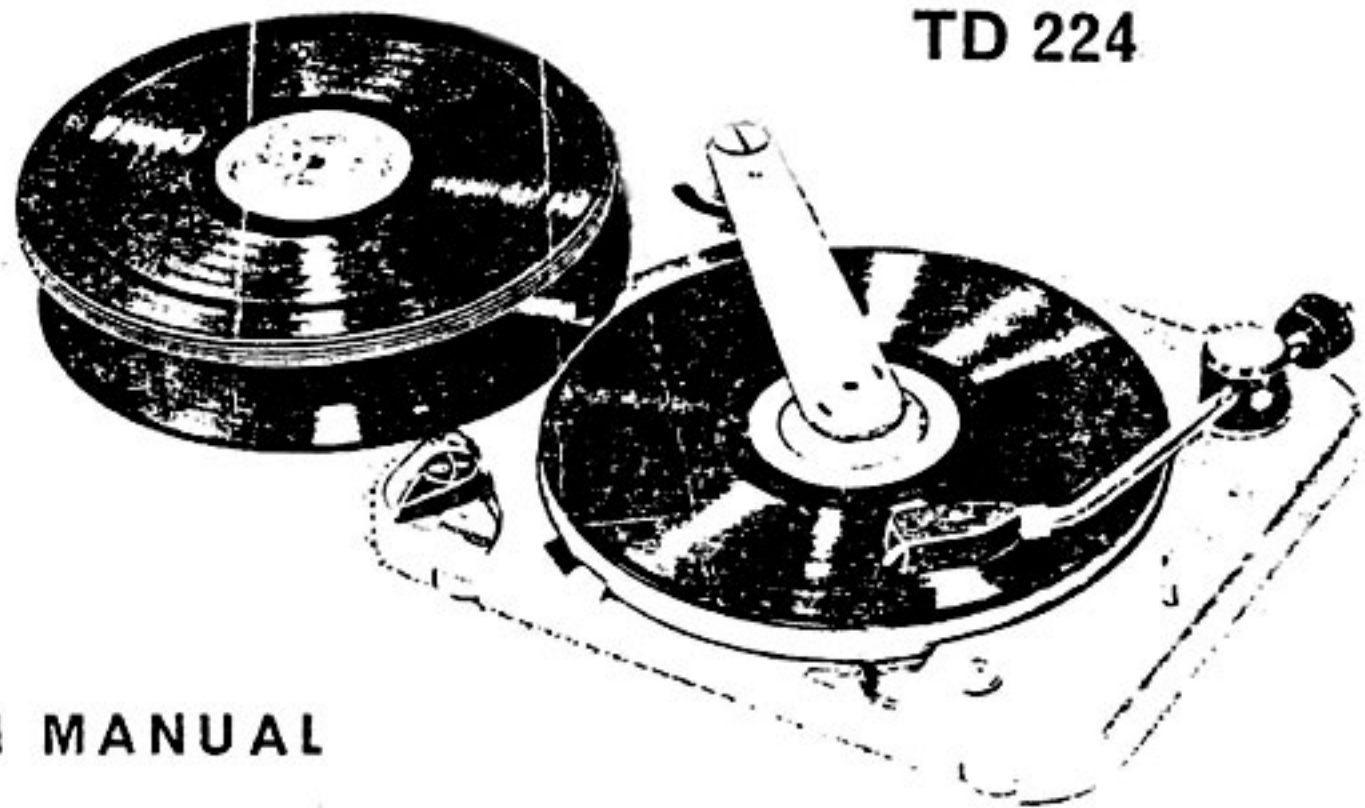

INSTRUCTION MANUAL

You are now the owner of one of the finest THORENS turntables the **TD 224 Masterpiece turntable and automatic record changer.**

Here, for the first time, the convenience of fully automatic record handling has been obtained without impairing any of the all important features of a true transcription turntable, for the closest approach to live music.

Here advanced automatic features greatly simplify the operation of a professional turntable and contribute to insure full protection to your precious records.

The purpose of this booklet is to show you how to get the most satisfaction out of this entirely new precision instrument made by master Swiss craftsmen. Take a few minutes to carefully read every page before performing the corresponding operation: unpacking, installation, final adjustments before play, operation. You will find this a very worthwhile investment of your time.

Perfectionists and lovers of advanced precision engineering, you will find a wealth of information in this manual and gain a thorough knowledge of your THORENS turntable. Given a reasonable amount of care, it will give you perfect functioning indefinitely.

Fig. 1

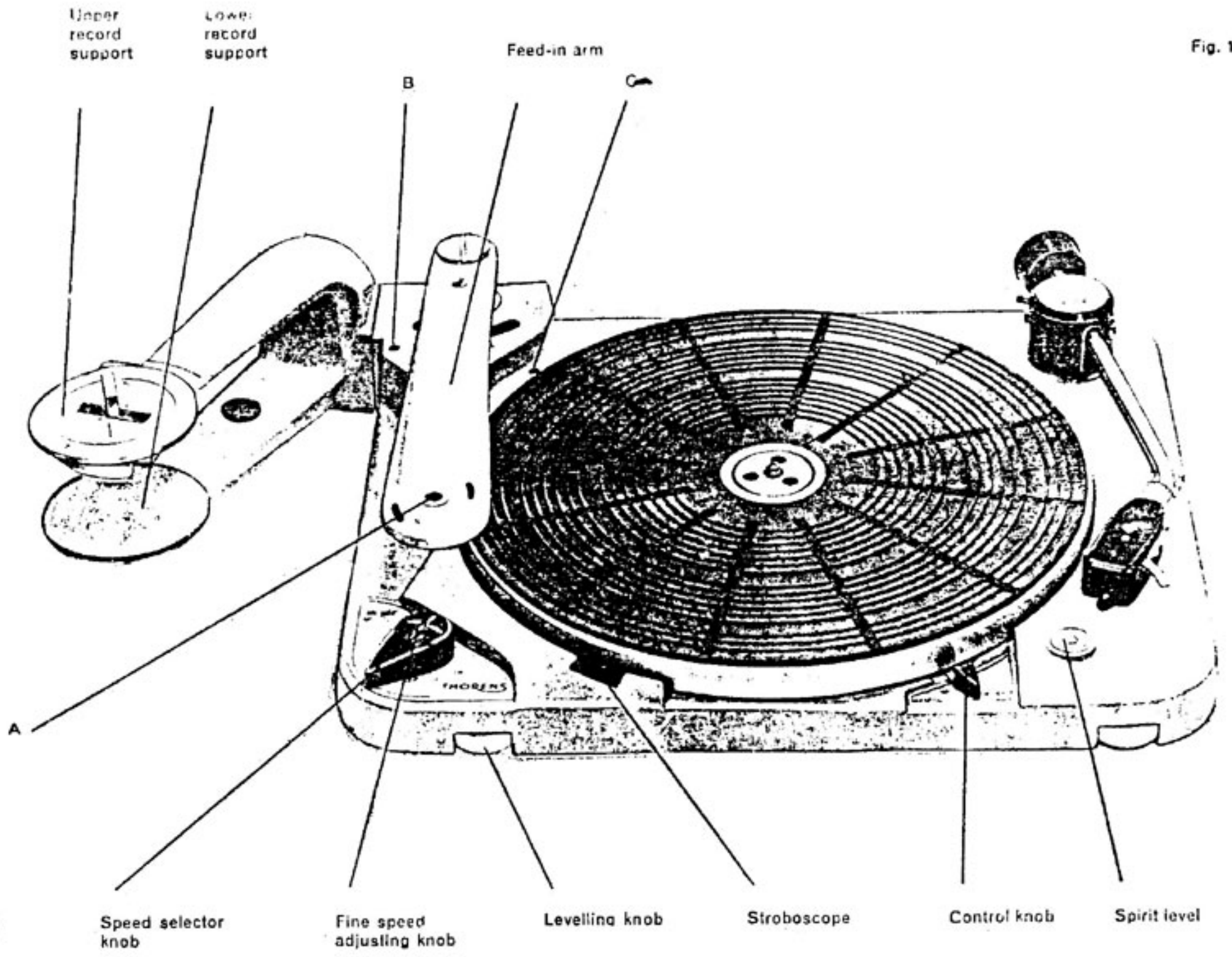

Table of contents

	PAGES
Introduction	2
Unpacking	6
Installation	8
Power supply—electrical connection	11
Cartridge installation and connections	13
Cartridge adjustment	14
Pick-up arm adjustment	15
Operation	17
Summary of the operating instructions	17
Manual stop during play	20
Manual operation	20
Fine speed adjustment and stroboscope	21
Record cleaning device	22
Record dimensions	23
Service adjustments	24
Pick-up arm adjustment	24
Record feeding mechanism	25
Interruption of power supply	26
Maintenance	27

A few do's and don'ts to be considered to get the most satisfaction out of your TD 224 turntable:

- DO:**
- read this manual thoroughly
 - follow the corresponding instructions step by step.
 - give special attention to the paragraphs marked with « caution ».
 - handle and operate your turntable as a precision instrument is supposed to be.
 - explain its simple operation to children (and the uninitiated) to prevent mishandling due to curiosity and lack of knowledge.
 - handle your records as gently as your TD 224 does.
 - keep them clean with the help of modern record cleaning devices. (See page 22).
- DON'T:**
- make electrical connection without consulting instructions.
 - **ever interrupt the record changing cycle.**
 - handle records on the supports or on the turntable platter during the record changing cycle.
 - remove records from the feed-in arm.
 - manually stop the turntable platter (this could result in the drive belt disengaging).
 - overload with records.
 - play automatically records with non-normalised central hole (See page 23).

1. You have already placed the carton top-side up and opened.
2. Take care that this manual and template CB 1856 are not misplaced.
3. Remove corrugated spacers A and B, paper C and lateral wedge D (see Fig. 2, page 7).
4. Take the complete unit out of the box, holding it by the two longer sides of the base plate (front and back sides), and place it on a table. (Caution: protect table with cloth or paper).
5. Lift the feed-in arm until square wedge E can be removed over this arm.

Leave the cardboard shipping ring F in position, between the turntable platter and the unit plate until the TD-224 is completely installed for maximum protection of turntable main shaft and bearing.

6. Take the record support bracket out of the box. Box G contains the mounting hardware and accessories delivered with the unit.

IMPORTANT NOTICE

Save the complete packing for possible re-shipment. The TD-224 is a heavy piece of equipment and would be seriously damaged if forwarded in an improvised packing. (Please see our warranty conditions on the enclosed card).

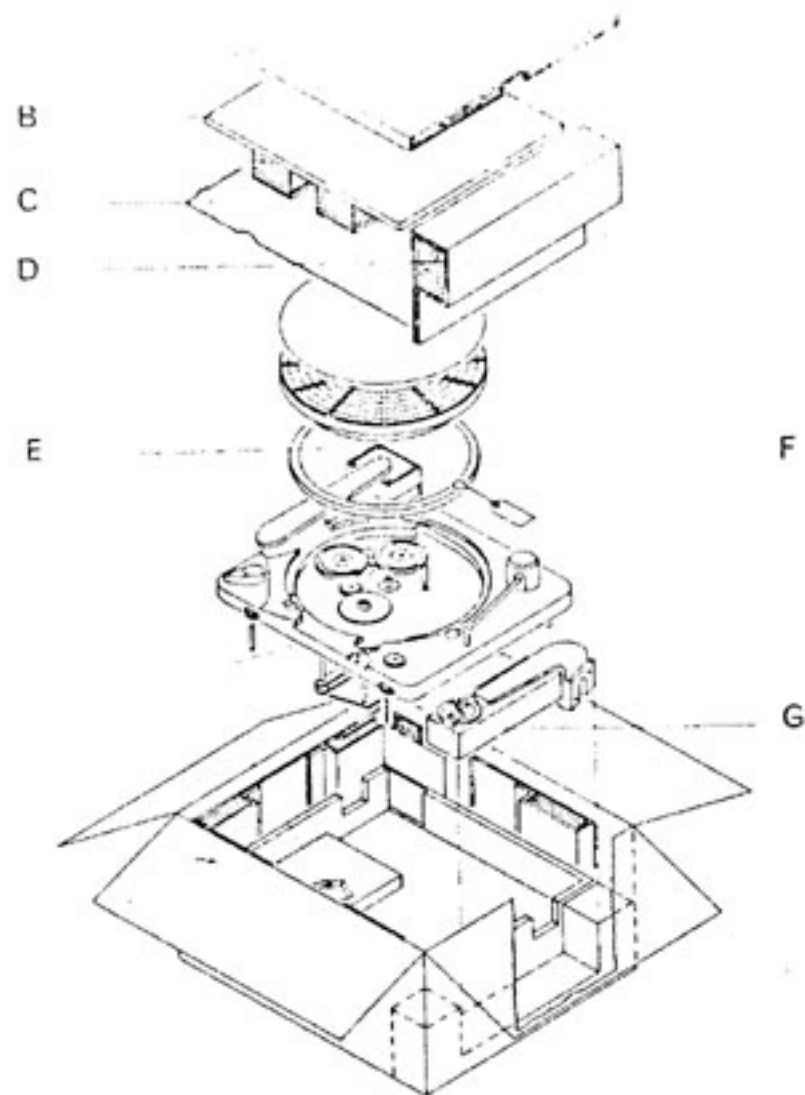

Fig. 2

packing

After the turntable has been placed into the box according to Fig. 2 and the top cover closed with adhesive paper strips, turn the box upside down and open the bottom cover. Check that all wedges and accessories are in the position corresponding to this illustration.

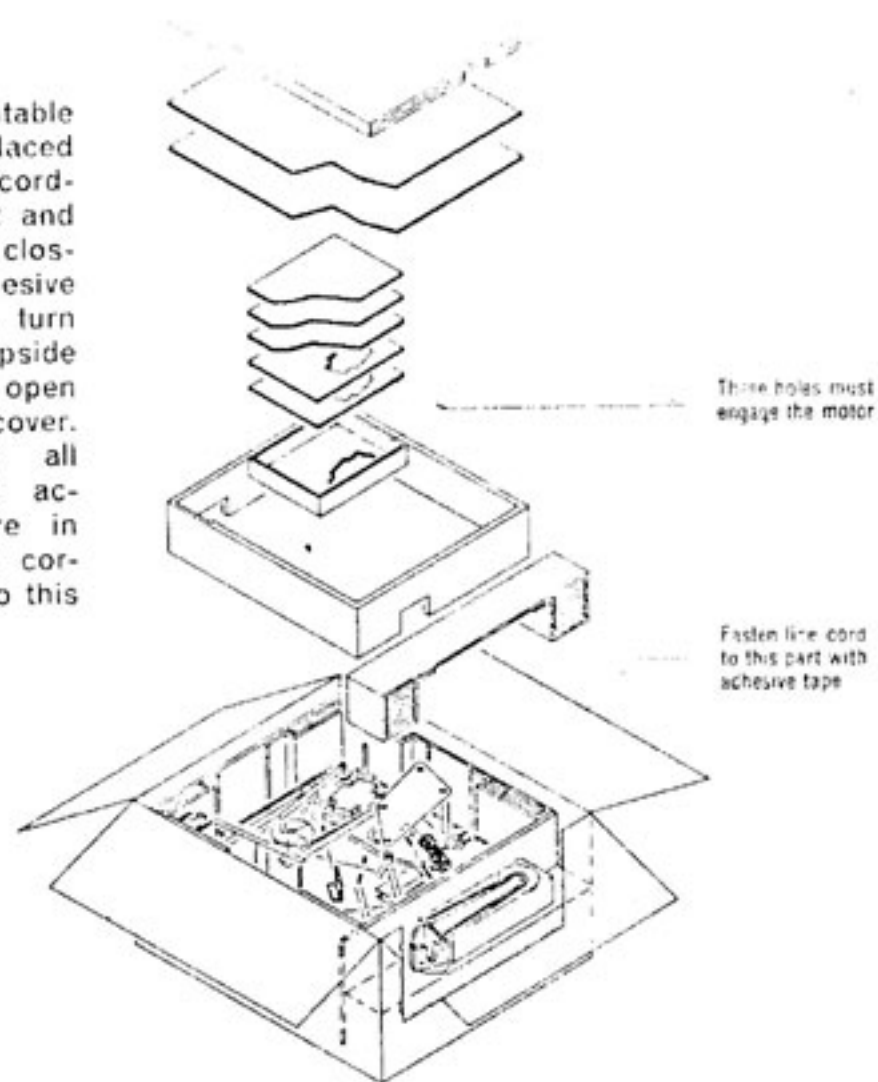

Fig. 3

Installation

1. MOUNTING THE RECORD SUPPORT ON THE BASE PLATE

1. Place the left side of the unit slightly over the edge of the table supporting it.
2. Remove the special wrench (Part No. CB 1617) from the underside of the record support and the bolt (Part No. M 8 x 20 VSM 12364) fixed with tape from the slot in the support.
3. Place the flat part of the handle of the wrench on the threads of the bolt between the base plate and the head of this bolt. Turn the bolt in until the wrench handle is just clamped between the base plate and the head of the bolt and remove the wrench. This positions the bolt to accept the record support.

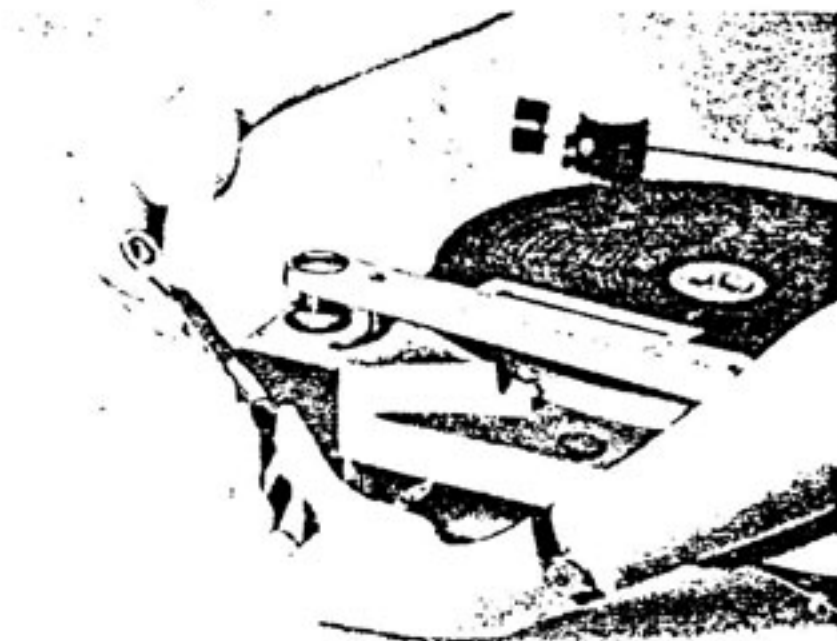

Fig. 4

the slot in the record support will slide over the bolt. Slide the record support down over the bolt so the bolt reaches the top of the slot. Press the record support on to the guide pins and up against the base plate.

5. Hold the record support in position with the right hand, turn the bolt with the left hand and secure it with the wrench.

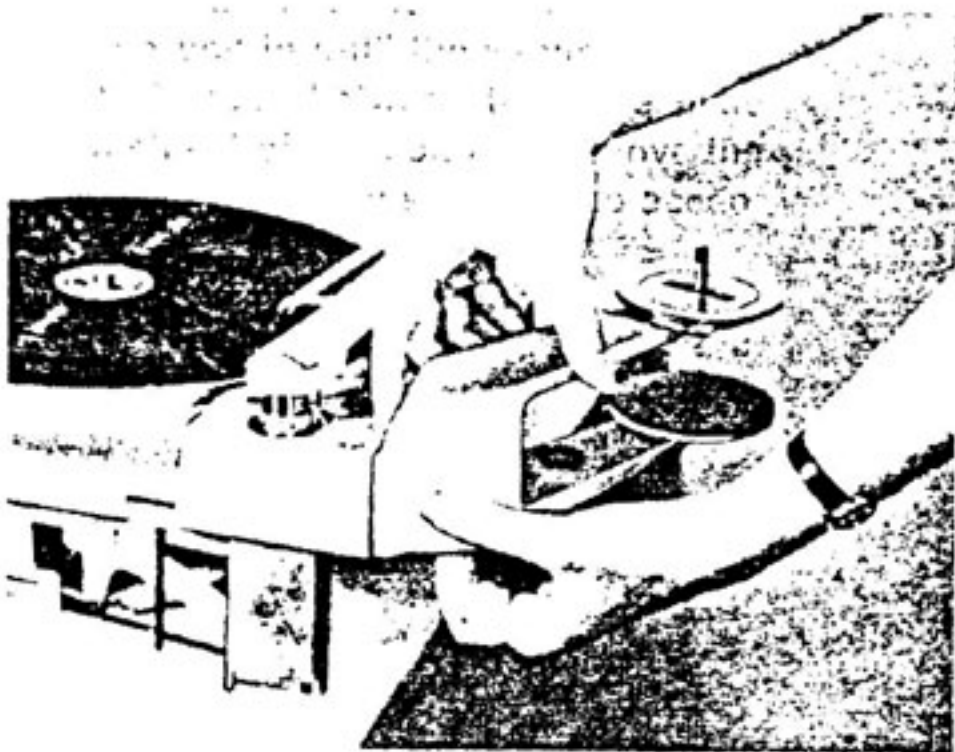

Fig. 6

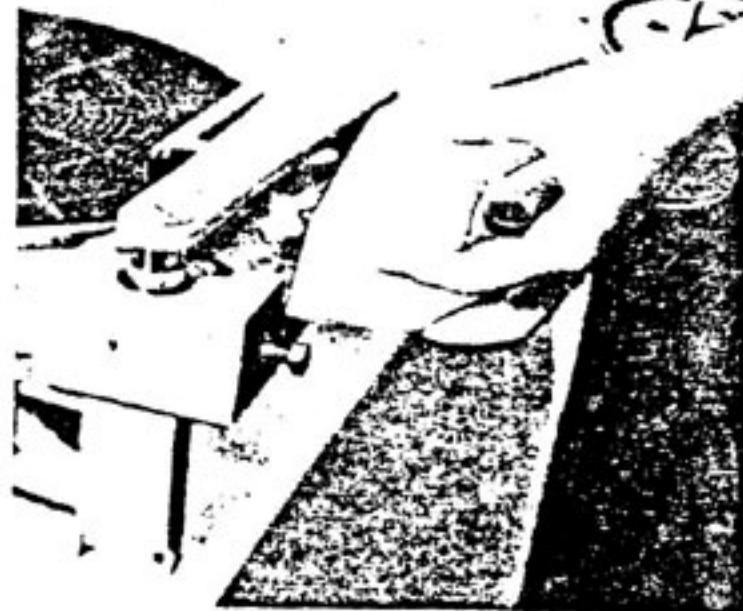

Fig. 5

6. Replace the wrench to its storage place under the record support bracket.

2. MOUNTING THE TURNTABLE ON BASE OR MOUNTING BOARD

If a Thorens base is not used, the TD-224 turntable should be mounted on a plywood mounting board of not less than 3/4" thickness and cut out according to template No. CB 1856 provided.

If the unit is to be installed into a cabinet, the mounting board should be made as level as possible. The cabinet itself should be very stable to minimize the transmission of floor vibrations.

If necessary, additional protection against acoustic feedback and floor vibrations may be obtained by mounting the board freely on thick rubberhair or foam rubber mats.

SHOCK MOUNTING

The TD-224 turntable should be mounted on the four rubber dampers furnished (Part No. CB 909) according to cut view of template No. CB 1856.

LEVELLING

Levelling of the unit should be made by revolving the four knurled knobs protruding from the periphery of the base plate; when the bubble of the spirit level is centered, the top surface of the turntable platter is level.

When levelling the TD-224, make certain that the weight is evenly distributed on the four rubber dampers.

It is neither necessary nor desirable in most cases to fasten the heavy unit to the mounting board or to the accessory base. Four washers and eight nuts (Parts No. F 1191 and M 5 VSM 12707) adapted to the four threaded mounting studs are available as an accessory for special installations. A substantial play should be left between these washers and the unit mounting board after the unit has been levelled, otherwise acoustic feedback may occur.

3. FINAL PREPARATION BEFORE ELECTRICAL CONNECTION IS MADE

Follow the directions on the tag attached to the unit proceeding as follows:

1. Make certain that the speed selector is set in the «0» position.
2. If necessary, gently push the feed-in arm to the left, hold the turntable rubber mat by the left and right side and lift the whole turntable platter about 1" up. Then hold firmly the turntable platter itself with both hands and remove it from the unit.

The turntable should be lifted vertically to prevent damage to the bearing and care should be taken to prevent dust or lint from collecting on the shaft.



Fig. 7

3. Remove the cardboard shipping ring from the unit plate and store it in the TD-224 carton for possible shipping use in the future.
4. **Power supply.** As supplied for **USA** and **Canada**, the TD-224 turntable motor is set for 60 cycle, 100 to 120 volt operation.

ADAPTATION TO OTHER POWER SUPPLIES

When loosening the commutator screw and removing the plastic cover plate, when existing, the voltage commutator will be within reach. Fasten the commutator screw into the position corresponding to the voltage of the power supply.

For 50 cycle operation, the motor pulley should be reversed on the motor shaft according to the following drawing:

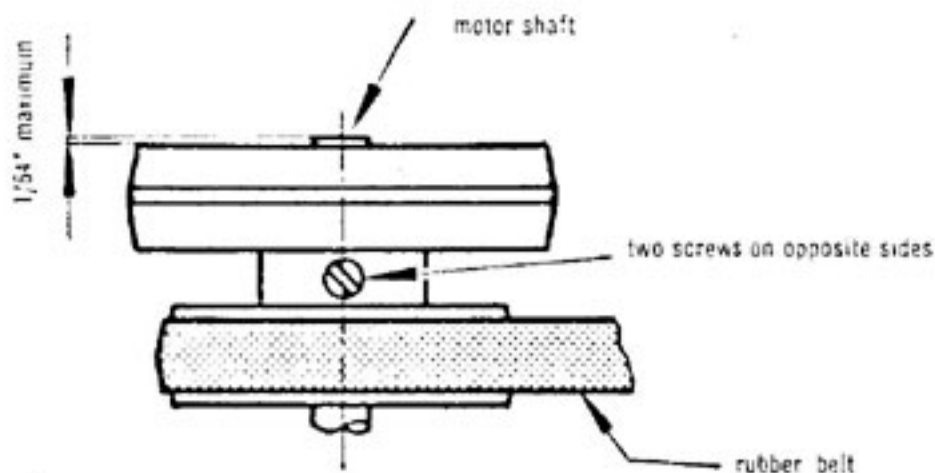

Fig. 8 Position of motor pulley for 60 cycle operation

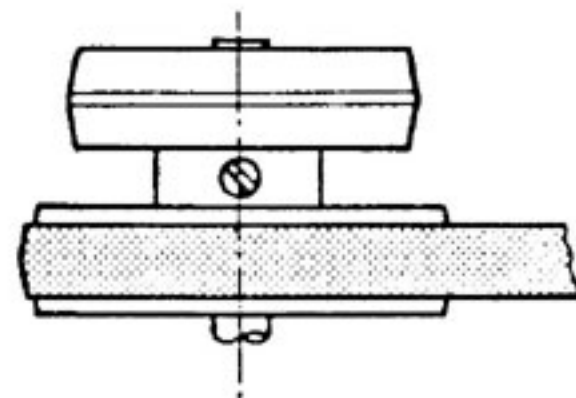

Fig. 9 Position of motor pulley for 50 cycle operation

IMPORTANT NOTICE When locating the motor pulley on the motor shaft, observe the 1/64" space indicated on Fig. 8. The motor pulley has been dynamically balanced to these very close tolerances at the factory. Therefore tighten the black screw first and then the nickel plated one.

4. ELECTRICAL CONNECTION

Make certain that the speed selector knob is set in a « 0 » position. Then replace carefully the turntable platter onto the unit. **Make certain that the shaft is vertical** when entering the bearing well to prevent any undue stress which might cause permanent damage.

The Power cord should be plugged into a receptacle which is independent of any « ON & OFF » switch. Do NOT use any receptacle on the pre-amplifier or amplifier unless it is « HOT » or independent of the « ON & OFF » switch of the pre-amplifier or amplifier. This is to eliminate the possibility of the power supply being cut off during a change cycle. If, however, power is interrupted during a change cycle, see special notes under « Interruption of power supply » (service adjustments, page 26).

Cartridge installation and connections

If a cartridge has been purchased which has been professionally premounted into the Thorens plug-in shell, disregard the following:

The aluminium plug-in shell offers enough space and the necessary mounting hardware to suit any standard pick-up cartridge:

- 3 sets of two spacers of different heights: 3, 6 and 8.5 mm
- 6 sets of two screws of different lengths
- 10 F 1132 washers

It is generally advisable to mount the cartridge on the slide plate after it has been removed from the plug-in shell. One F 1132 washer should be installed between each of the two chosen spacers and the slide plate. The specific mounting instructions furnished by the cartridge manufacturers should be followed EXCEPT that the screws — listed above — MUST be used. (The mounting screws supplied with US cartridges are for US standards and will not fit the metric threads used on Thorens units.)

CONNECTIONS

Four separate colour coded leads are already soldered to the terminal pins in the shell:

- Red — Right channel positive (hot)
- Green — Right channel negative (shield)
These two leads constitute also the normal mono channel
- White — Left channel positive (hot)
- Blue — Left channel negative (shield)

Internal wiring

The two insulated shielded leads of the pick-up arm:

- Grey — Right channel
- Black — Left channel

and the separate ground lead (colourless insulation) are connected to a normalized 5 prong female plug (Din 41524) fastened underneath the unit plate in the arm base.

- 1 — Right channel positive
- 2 — Ground of tone arm and unit plate
- 3 — Left channel positive
- 4 — Right channel negative
- 5 — Left channel negative

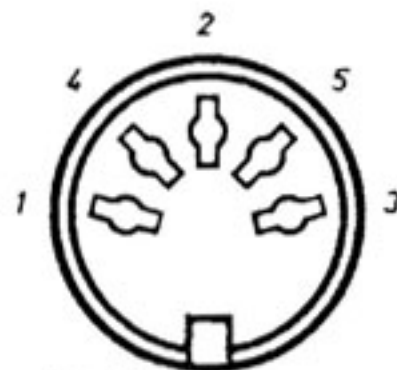

Fig. 10

Output connections

A removable pick-up output cable is furnished with each turntable. It consists of:

- a 5 prong male plug (Din 41524)
- two shielded leads with standard male phonoconnector plugs
 - black: right channel
 - white: left channel
- one insulated (black) ground lead with connector.

IMPORTANT

The positive lead and shield of one channel are completely insulated from the positive lead and shield of the other channel and also from the metal parts of the arm, thus allowing a true five wire connection to the amplifier.

The metal parts of the arm, including the aluminium shell and the unit plate, are connected to the insulated black ground lead which must be connected to the common ground terminal of the amplifier or preamplifier.

CARTRIDGE ALIGNMENT

Stylus overhang

Slide the cartridge mounted on the sliding plate inside of the shell to bring the needle tip in alignment with the two notches on the sides of the shell. This will insure the minimum tracking error.

Lateral alignment

The cartridge should be mounted parallel and centered between the two side walls of the shell.

Height

When the cartridge is correctly mounted, the needle tip should protrude out of the shell $3/32$ " (2 mm) to $7/32$ " (5 mm).

Pick-up arm adjustments

MOUNTING THE COUNTERWEIGHT

As a precaution against damage in transit, the counterweight is packed separately, already mounted on the removable back tubular part R of the arm, with the set screw S. Do not remove the counterweight from this tubular part or the internal spring plate and nylon pad, which ensures smooth friction, will fall out.

Slide the back tubular part R, which supports the counterweight, onto the pick-up arm extension and lock it in position with set screw S. Do not overtighten as the arm extension is mounted in rubber.

Fig. 11

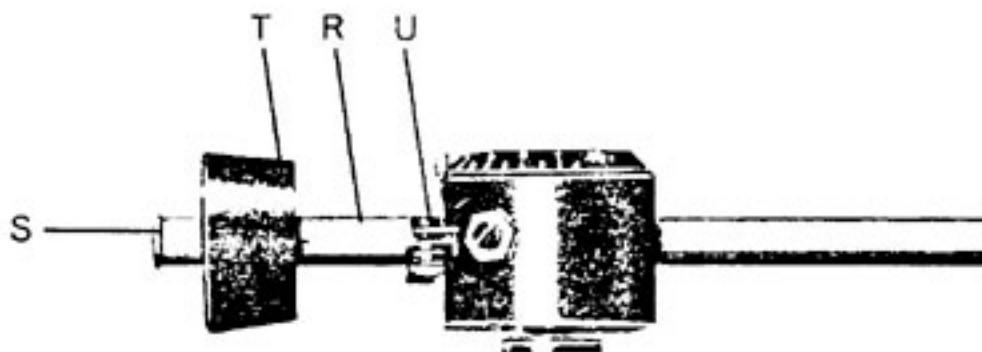

FITTING THE SHELL

This operation is best performed when the arm is clamped in the arm rest. Insert the shell plug into the arm socket, allowing the locating pin to enter the slot. Press inward and tighten the locking nut firmly, but not more than necessary.

BALANCE

The arm has been designed to allow a precise longitudinal and lateral balance simultaneously for pick-up cartridges weighing between 5 and 19 grams.

- Move the stylus force adjustment lever back as far as possible to the rear of « 1 gram ».
- Position the arm so that the stylus tip is between the arm rest and the turntable platter.
- Move the counterweight with the right hand (while maintaining the lateral position of the arm with the left hand to avoid damaging of the stylus), until the arm assumes a horizontal position. (The precise position of the counterweight is easier to locate if it is turned clockwise while moving it forward or backward).

Comment: By turning the counterweight «counterclockwise», as stated in the original draft of the instructions, it is possible to loosen the set screw S.

STYLUS FORCE ADJUSTMENT

After balance of the pick-up arm has been achieved, slide the stylus force lever to the prescribed weight on the stylus pressure scale as recommended by the cartridge manufacturer.

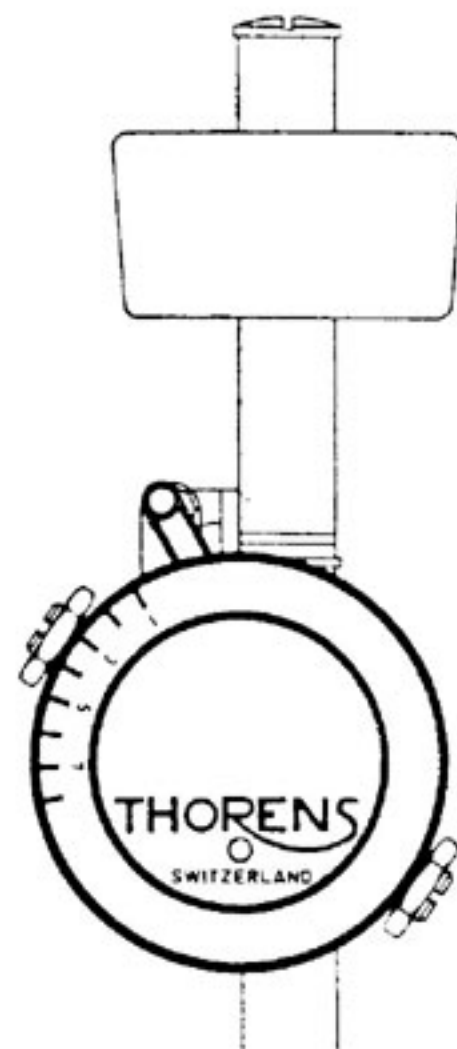

Fig. 12 Balance in this position of the stylus force adjustment lever.

OPERATION

Summary of the operating instructions

The Thorens Model TD-224 turntable will play automatically any number of records up to eight (see the paragraph underneath « Maximum height of the stack »), provided they have the following common characteristics:

- same speed (78, 45, 33 $\frac{1}{3}$ or 16 rpm)
- same groove shape (microgroove or 78 rpm groove)
- same centre hole diameter (9/32" or 1 $\frac{1}{2}$ ")

Under the above conditions, records of any diameter between 7" and 12" may be intermixed in any order.

- 1 Adjust the centering post on the record support for normal centre hole records (9/32") or large hole records (1 $\frac{1}{2}$ ") by pushing on wings W.

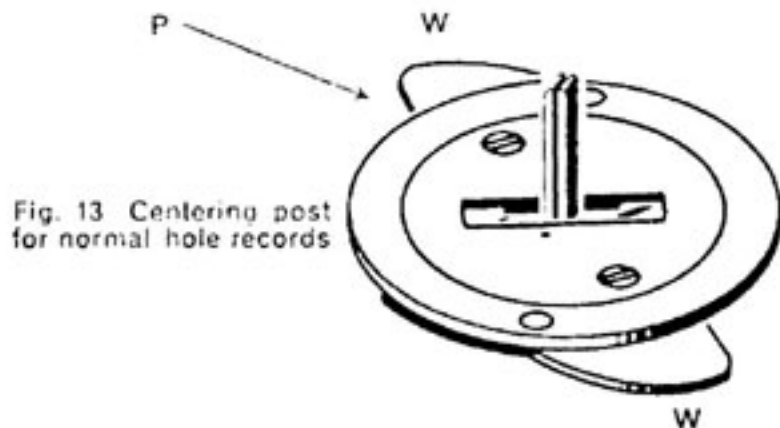
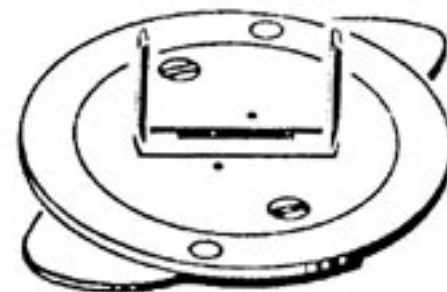

Fig. 13 Centering post for normal hole records

Fig. 14 Centering post for large hole records



- 2 Carefully stack the records to be played on the upper record support in the desired order: the first record to be played will be the one on the top of the stack.

Maximum height of the stack: 3/4" (20 mm)

The centering post should protrude about 3/32" (2 mm) above the top of the stack.

- Push the whole stack of records in the direction of arrow P against the centering post (See Fig. 13)
- ③ Move the speed selector knob to the desired speed and verify that the proper needle is used for the type of records to be played.
- ④ For large hole records, the built-in spring loaded adaptor is brought into playing position by pushing down and revolving it clockwise. To return it to not-use position, push down and turn counterclockwise.
- ⑤ Check that the pick-up arm is disengaged from the clamps of the rest post.
- ⑥ Move the Control knob to the « Start-Reject » position and hold it in this position a few seconds before letting it return to its rest position.

From this moment, the turntable functions automatically until all the records are played. After the last record has been played and rejected, the machine will execute one complete cycle without a record before it shuts itself off.

● **CAUTION:**

Do not cut off power supply to turntable until this last cycle has been completed and it has shut itself off

(See note under « Interruption of power supply », Service adjustments page 26).

REJECT

To reject a record during play, move the control knob to the « Reject » position.

REPEAT

To repeat a record, move the control knob to the « Manual » position during play. At the end of this record, the auto-trip mechanism will not operate and the pick-up remains in the lead-out groove. The pick-up may then be manually returned to the beginning of the same record. The control knob should then be returned to its rest position.

LOADING OR UNLOADING THE TURNTABLE DURING PLAY

Additional records may be placed on the upper record support, or records may be removed from both record supports whilst the pick-up is playing. To avoid noise in the loudspeakers, it is better to manually place the pick-up in its rest position during such operations.

● **CAUTION!**

Do not try to handle records on the supports or on the turntable platter during the record changing operations, or severe damage may occur to these records.

● **MANUAL STOP DURING PLAY**

The turntable can be stopped **during the play of a record only** by returning the pick-up arm manually to its rest post and moving the Speed Selector knob to an « O » position.

To resume the play of the same record:

- Move the Speed Selector knob to the desired speed.
- Move the Control knob to the « Manual » position to start the turntable.
- Position the pick-up manually to the desired part of the record.
- Return the Control knob to its neutral rest position.

To resume play with the next record or a new pile of records:

- Move the Speed Selector knob to the desired speed, if necessary.
- Move the Control knob to the « Start » position.
The record on the turntable will be rejected and the next one brought in the playing position.

● **Important**

The Speed Selector knob should only be moved to a « O » position during the playing of a record or when the turntable is stopped. **Do not move the knob to a « O » position during the record changing operation.** (See note under « Interruption of power supply », Service adjustments, page 26.)

REMARK FOR 78 RPM RECORDS AND SOME LP RECORDS

The first record, when rejected, will bounce slightly upon landing on the thick rubber cushions of the lower record support. To benefit from an air cushion action from the first record on, a record may be placed directly on the lower record support when loading the turntable.

MANUAL OPERATION

The TD-224 turntable can be used manually as a transcription turntable:

1. Position the Speed Selector knob at the desired speed.
2. Move the Control knob to the « Manual » position.

The turntable starts and the pick-up, entirely disengaged from the cycle mechanism, is free to be positioned manually on the record.

3. To suppress the slight friction of the auto-trip mechanism at the end of a record played **manually**, move the pick-up to the central run-out groove before positioning it on the record.
4. To **stop** the turntable, **first** move the Control knob to its neutral rest position and then move the Speed Selector knob to a « O » position.

NOTICE ON MANUAL OPERATION

When playing a record **manually** with a light weight pick-up (under $3\frac{1}{2}$ grams), it is not recommended to move the Control knob to the « Reject » position or let the auto-trip mechanism operate: the cycle mechanism, when resetting the auto-trip lever, may push the stylus out of the run-out groove at the end of the record.

No record should be put on the upper record support during **manual operation**, otherwise, if the « Reject » or the auto-trip mechanism are actioned, the feed-in arm would drop this record on the pick-up arm.

FINE SPEED ADJUSTMENT AND STROBOSCOPE

The fine speed adjustment knob, coaxially mounted on the Speed Selector knob, allows a most precise adjustment of the speed over a margin of about $\pm 3\%$.

Two stroboscopic patterns may be seen through the lucite covered aperture on front of unit plate:

- for $33\frac{1}{3}$ rpm and 60 cycle power supply
- for $33\frac{1}{3}$ rpm and 50 cycle power supply

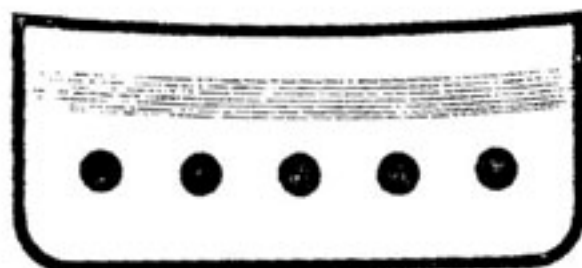

$33\frac{1}{3}$ rpm for 60 cycle

Fig. 15

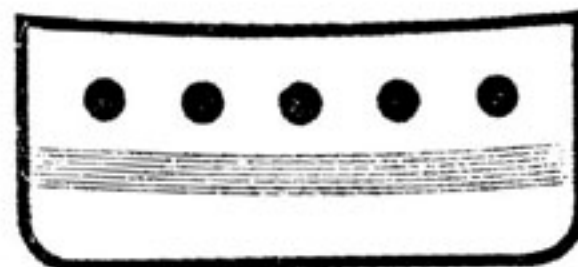

$33\frac{1}{3}$ rpm for 50 cycle

When adjusted to the nominal speed at $33\frac{1}{3}$ rpm, the three other speeds will be exact within $\pm 0.5\%$.

Notes on the use of the stroboscope

- a) The stroboscope of the TD-224 turntable permits control and adjustment of the speed while the record is being played. Thus, for maximum accuracy, the speed should be adjusted while the record is actually playing.
- b) During the warm-up period of about 10 minutes, the speed may progressively vary a fraction of 1 % about the nominal speed. Though such extremely slow speed variations cannot be detected by the ear, critical transcription work should preferably be made when the motor has reached its normal operating temperature.
- c) Owing to the very large scale and high precision of the stroboscope, extremely small differences of speed as compared to the nominal value will be made visible though entirely undetectable by ear.

For example, at 60 cycles a 1 % speed change would appear as a 72 dots per minute drift on the stroboscope. This 1 % variation (or 72 dots) would only vary the pitch $\frac{1}{6}$ of a semitone. A speed difference of about $\frac{1}{4}$ of 1 % normally encountered between the beginning and the end of a 12" record, using a modern cartridge with less than 4 grams stylus pressure, will correspond to a 18 dots drift per minute and a pitch variation of $\frac{1}{24}$ of a semitone, well within NAB Standards.

At 50 cycles, the corresponding number of dots are respectively 60 and 20 each minute.

For special technical work, the speed may easily be maintained constant to the highest accuracy of 0,1 % throughout the playing of a record thanks to the precision speed adjusting device which allows a permanent checking of the speed when the record is actually playing.

RECORD CLEANING DEVICE

The new extremely light weight pick-up cartridges require new record cleaning methods.

A thorough cleaning of a new record or of older records may be made with the help of special devices, such as the Parastatic Disc Preener or the Parastat of Cecil E. Watts Ltd. Both require an appreciable pressure on the record and, for this reason, cannot be used during play.

To keep the record clean during play and to eliminate static charges, the TD-224 turntable incorporates a patented continuous record cleaning device.

It is advisable, before playing each stack of records, to remove the special brush from the record feed-in arm, and to briskly brush a finger against the nylon plush to remove accumulated dust and dirt. A trace of the anti-static agent supplied as an accessory should be applied occasionally to the plush.

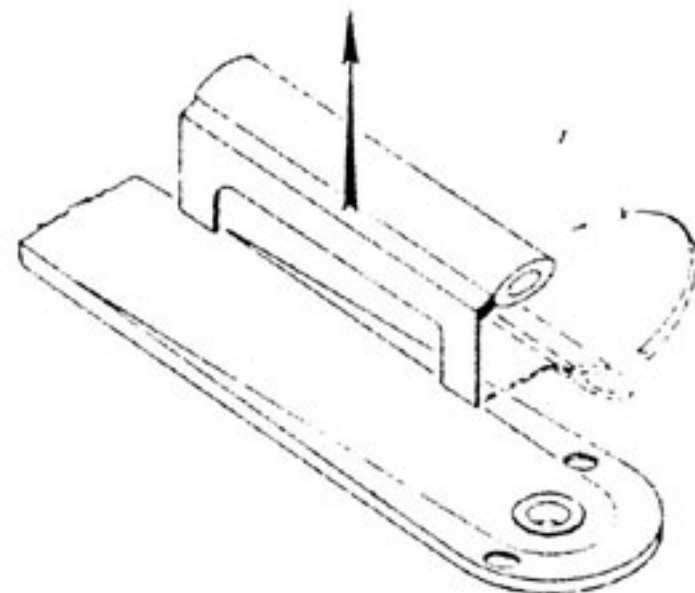

Fig. 16 Removing the record cleaning device from the feed-in arm.

RECORDS

The record feed-in mechanism has been designed to carefully handle all standard records. Therefore, for optimum results, the dimensions of the central hole of each record should be the following:

Diameter: 0,230" to 0,290" or 7,15 to 7,4 mm

Thickness: 0,06" to 0,12" or 1,5 to 3 mm

A burr around the central hole of a new record may lead to irregularities in the cycle operations. It should be carefully smoothed.

45 rpm records with an inbuilt adaptor for 9/32" centering post should be played without removing this adaptor, if this removal cannot be made without damaging their central hole.

PICK-UP MUTING SWITCH

Both channels of the pick-up are short-circuited during the record changing operations. **They are not short-circuited in the rest position of the pick-up arm to allow the immediate manual play.**

SERVICE ADJUSTMENTS

The following notes should allow the owner of a TD-224 turntable to make any minor adjustments that may become necessary for optimum performance.

PICK-UP LIFT

The pick-up lift has been adjusted at the factory to match any cartridge mounted according to the instructions of this manual (see page 14). If a new adjustment is necessary, turn screw U (see Fig. 11):

- clockwise to increase lifting height
- counterclockwise to decrease lifting height

Proper adjustment may be checked when the turntable is in the normal stop position:

- lift the turntable platter rubber cover slightly from the rim.
- bring the pick-up near the edge of the platter with the needle tip outside
- verify that the lower end of the lateral abutment of the plug-in head is from $1/32"$ to $1/16"$ (1 and 2 mm) above the platter surface (Distance h).

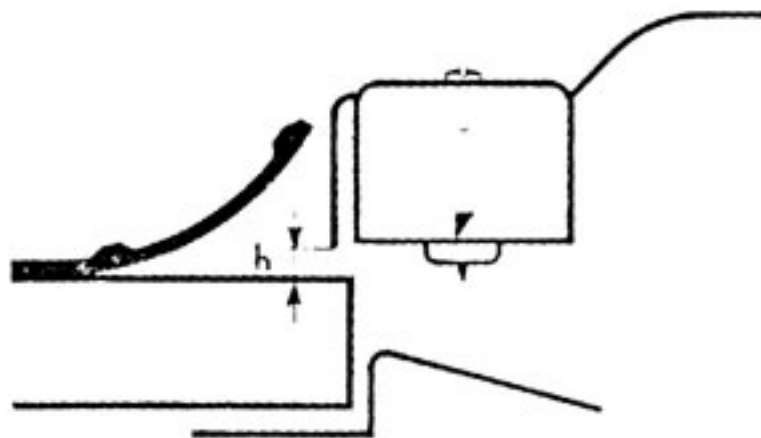

Fig. 17 Pick-up lift adjustment.

PICK-UP LANDING POSITION

The landing position of the pick-up should be approximately $1/8$ " from the edge of a record. This position is determined by the lateral abutment of the plug-in head. To change the adjustment made at the factory:

- first untighten slightly the black screw on top of plug-in head.
- for a more outer landing position, pull the lateral abutment out of the head slightly.
- for a more inner landing position, push the lateral abutment into the head slightly.
- tighten the black set screw.

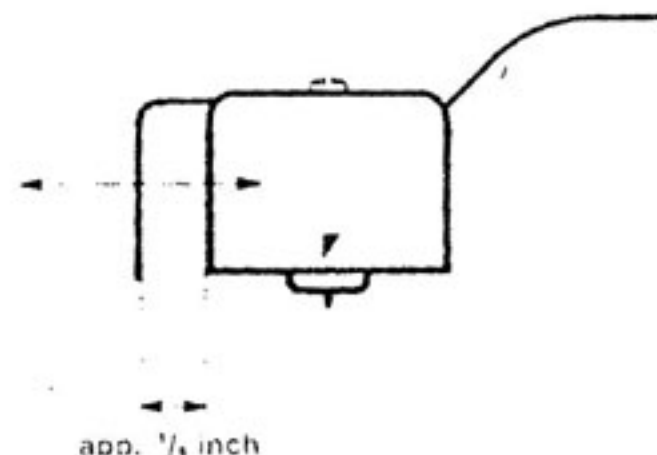

Fig. 18 Adjustment of the pick-up landing position.

PICK-UP ARM REST POSITION

The normal pick-up arm rest position, when the turntable has been stopped, is on top of the arm rest post. If the arm has been forced by accident and does not come to the above described position, it should be carefully forced in the suitable direction. If too much effort is necessary, the turntable should be returned to the nearest service station.

RECORD FEEDING MECHANISM

For correct automatic record handling, it is essential that the two lateral end positions of the feed-in arm be precisely adjusted.

This adjustment should be made, when the turntable is in its normal stop position, by turning screws B and C through corresponding holes on unit plate (See Fig. 1). **Do not turn the adjustment screws more than a few degrees in either direction.**

The exact centering of hole A on the feed-in arm with the upper support centering post is obtained by means of adjustment screw B. Turning screw B counterclockwise will bring the feed-in arm more to the left.

The exact centering of hole A with the turntable platter centre pin is obtained by means of adjustment screw C. Turning screw C clockwise will bring the feed-in arm more to the right.

IMPORTANT

The precise adjustment made at the factory should be modified only if difficulties with record handling are encountered and after a thorough examination of the corresponding records for thickness, hole dimensions and shape (see paragraph « Records », page 23).

INTERRUPTION OF POWER SUPPLY

If notwithstanding the precise instructions of this manual, the turntable has been stopped during the automatic record changing operation,

- or a) — by switching off or interrupting the power supply
- or b) — by moving the speed selector knob to a « O » position

the turntable might not be able to start again by itself.

Proceed as follows:

- or a) — switch on or reconnect the power supply
- or b) — move the speed selector knob to the desired speed
- move the control knob to the « Start-Reject » position

If the turntable does not start again by itself, gently lift the record feed-in arm by hand while helping the turntable platter to start.

If necessary, turn slightly the turntable platter counterclockwise.

MAINTENANCE

To remove the turntable platter from the unit, see page 11, § 3, N° 1 and 2

1. TURNTABLE SPINDLE

The turntable spindle revolves on special bushings and on a nylon thrust plate. A sufficient lubricant reserve is foreseen for the whole life of the unit under normal use conditions. If lubrication is necessary, use Caltex or Texaco Regal Oil B (ROB).

Notice. If through inobservance of the instructions of this manual dust, lint or grit have been allowed to come inside of the bearing, thoroughly wash both the bearing and the turntable spindle with the recommended oil.

2. IDLER WHEEL

The bearing of this wheel is of the oil retaining type and rarely needs lubricating. When necessary, introduce two or three drops of ROB oil on top of the bushing, between the stop ring and the wheel. The idler wheel should be perfectly free on its spindle; see that an axial play of about 1/64" is present between the stop ring and the wheel.

Due to the exclusive design of the turntable drive of the TD-224, as well as to the special synthetic rubber tread of the idler wheel, the latter will last indefinitely if the complete operating instructions of this manual are followed.

To remove the stepped pulley and the rubber belt, proceed as follows: (See Fig. 19 and 21.)

- remove the idler wheel from its spindle by loosening its stop ring.
- remove the large toothed wheel D from its spindle E by loosening its set screw.
- remove the complete cycle clutch plate from spindle E and from the abutment stud F and lay it aside on the unit plate without disconnecting the attached coil spring G.

3. STEPPED PULLEY

The bearing of this pulley is of the oil retaining type and rarely needs lubrication (about every 5000 running hours; no jamming is to be feared). However, on a new unit, a very silent running of this part may sometimes require some more oil than the limited supply that can be safely put into the bearing at the factory (otherwise oil spilling on the drive system could occur during transport). Lift the pulley with its spindle out of the bearing and introduce 4 to 6 drops of our special ROG oil into the well.

4. RUBBER BELT

The specially developed synthetic rubber belt running on very large diameter pulleys will not, under normal use, be subject to wear or deformation. Rubber traces on the pulleys should occasionally be taken away with denatured alcohol. At the same time the slight application of talcum powder on the belt with absorbent cotton will provide a silencing effect.

After service operations, reassemble the cycle clutch plate, engaging first its forked extremity into the abutment stud F and then its other end on spindle E.

Then fasten the large geared wheel on spindle E, the set screw against the flat spot on the spindle. See Fig. 19 for proper mounting of the idler wheel.

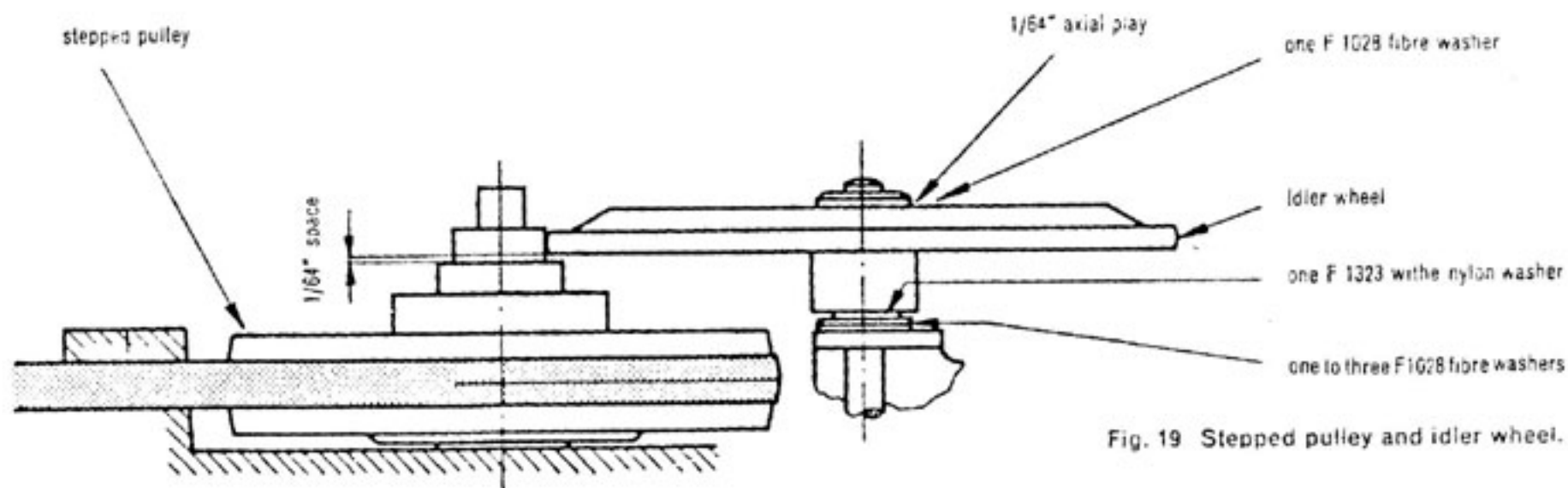

Fig. 19 Stepped pulley and idler wheel.

5. MOTOR

The motor bearings are of the oil retaining type with large oil reserve in felt pads. Under normal use conditions, the initial lubrication made at the factory should be sufficient for about 5000 hours' run. When the need for a new lubrication becomes apparent, proceed as follows:

Upper bearing

Place a few drops of ROB oil on top of the bearing where the shaft comes out of the top motor shield.

Lower bearing

Oil should be put on the lower part of the shaft, underneath the rotor. This lower part can be reached with a pressure oil can through the lubrication hole on the side of the bottom motor shield. (See Fig. 22, H.)

6. RECORD CHANGING MECHANISM

After a few years of intensive use, it is advisable to put some Caltex Starfak 2 grease on the cams, brass rollers, toothed wheels and guiding slots. Also put one drop of ROB oil on the articulations of the levers and into the two bearings of the main cam spindle.

The pick-up arm control plate I (See Fig. 22) and the two levers of the auto-trip mechanism should not be oiled.

IMPORTANT NOTICES

To oil too much and too often, or to oil other parts than those indicated above, is highly prejudicial to the functioning of the turntable.

For the perfect functioning of the drive system of the TD-224 turntable the following parts should be entirely free from any trace of oil or grease on their external working surfaces: the motor pulley, the stepped pulley, the two idler wheels, the rubber belt and the inner skirt of the turntable. Therefore any excess of lubricant may interfere with proper operation. If the presence of oil or grease on the mentioned parts is suspected, they should be thoroughly cleaned with a clean rag impregnated with denatured alcohol.

RECOMMENDED OILS

Do not use other lubricants than those indicated above. A lubrication-kit with recommended lubricants is available as an accessory at your franchised dealer.

Caution: Do not accept substitutes.

7. REPLACING THE NEON STROBOSCOPE BULB

1. Disconnect unit from AC current.
2. Remove the stroboscope mirror (See Fig. 22) by loosening the mounting spring.
3. Remove the retaining plate K.
4. Take out the complete bulb assembly and remove the plastic sleeve.
5. Replace the bulb with type:
NE 48 or Philips Z2W
6. See Fig. 20 for the exact location of the bulb assembly.

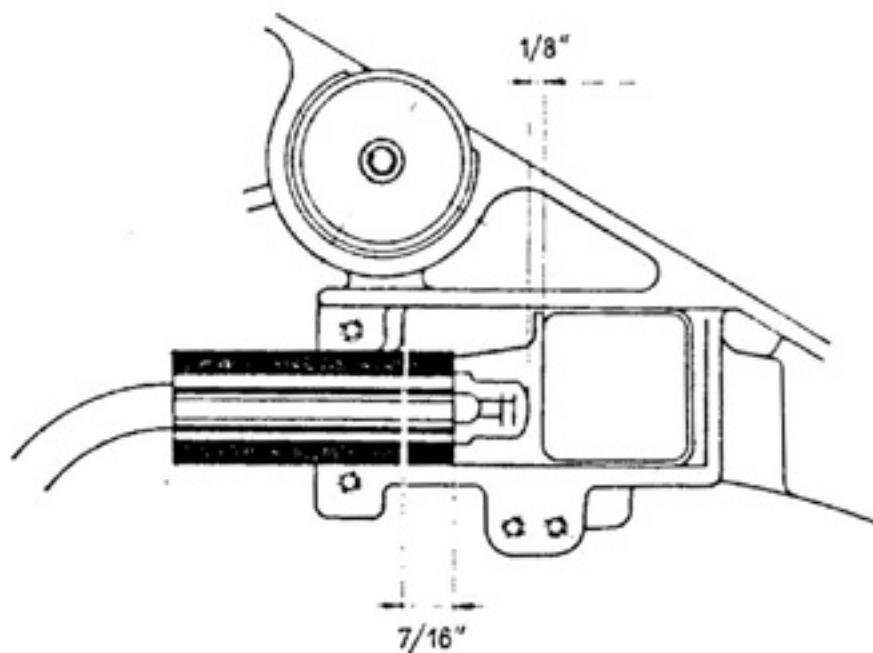
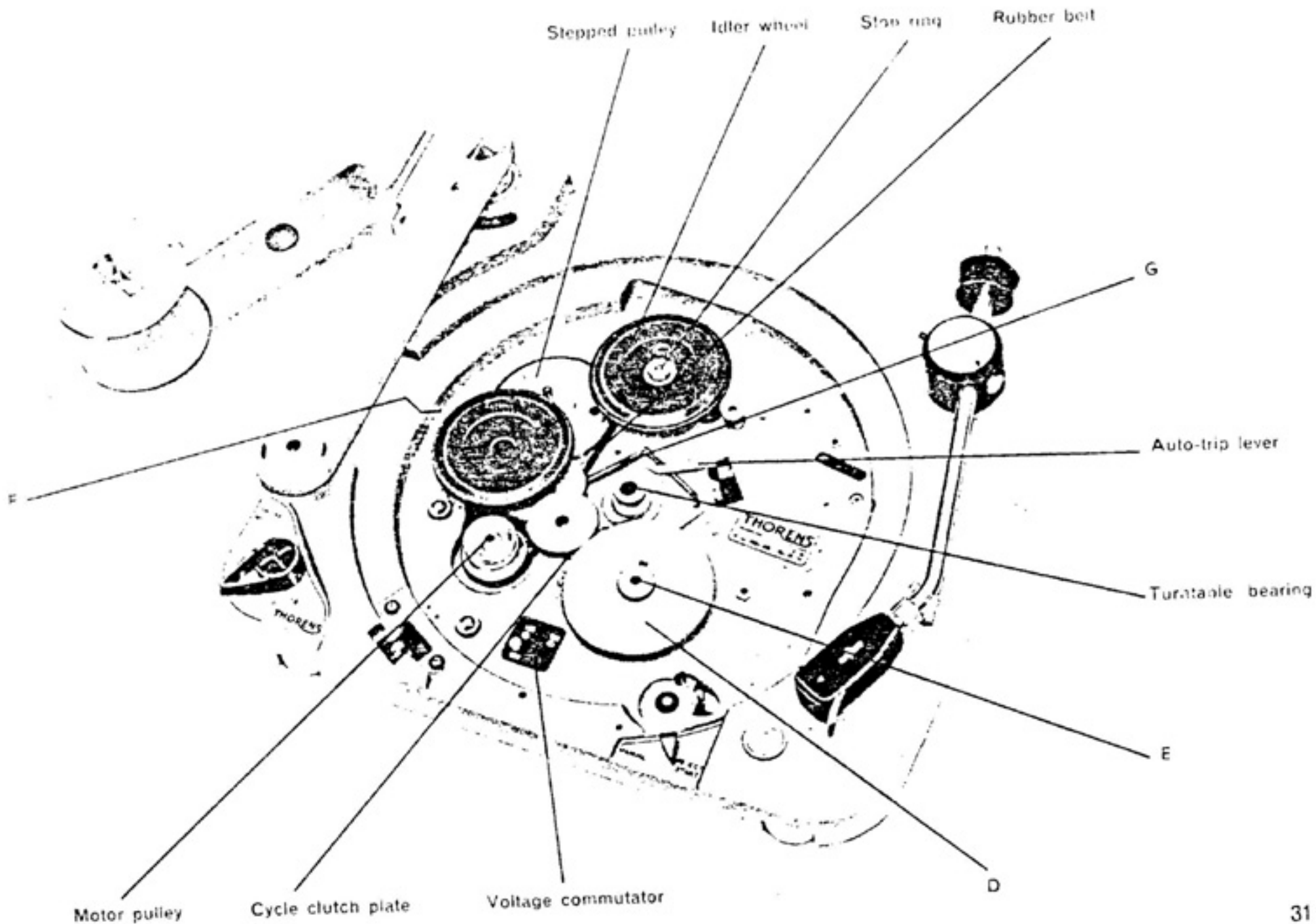

Fig. 20 Neon bulb.



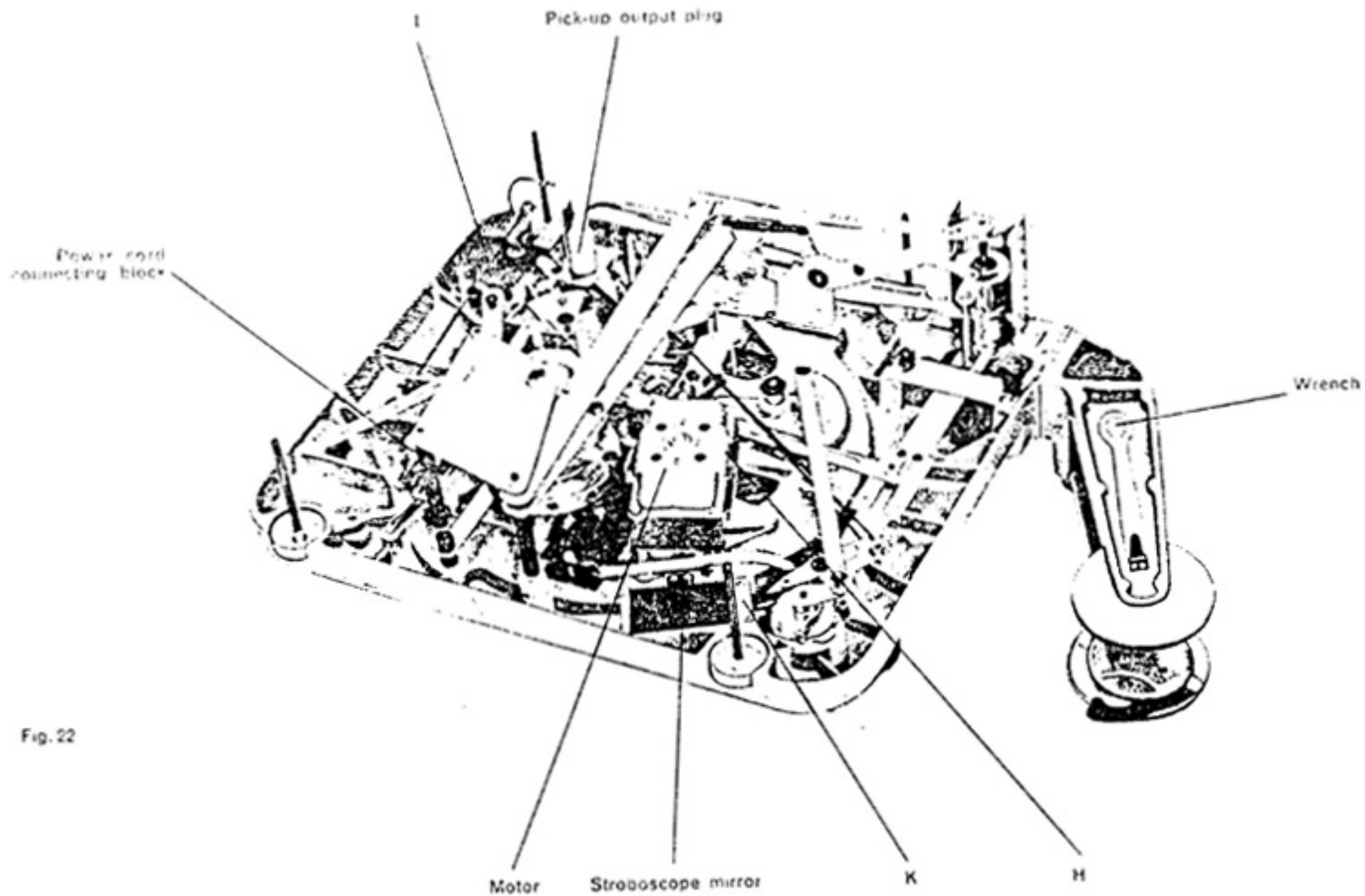

Fig. 22